



**NAMIBIA UNIVERSITY  
OF SCIENCE AND TECHNOLOGY**

**FACULTY OF COMPUTING AND INFORMATICS  
DEPARTMENT OF CYBER SECURITY**

<b>QUALIFICATION:</b> BACHELOR OF COMPUTER SCIENCE, BACHELOR OF COMPUTER IN CYBER SECURITY & BACHELOR OF INFORMATICS	
<b>QUALIFICATION CODE:</b> 07BACS, 07BCCS & 07BAIF	<b>LEVEL:</b> 5
<b>COURSE:</b> COMPUTER ORGANISATION AND ARCHITECTURE	<b>COURSE CODE:</b> COA511S
<b>DATE:</b> NOVEMBER 2025	<b>PAPER:</b> THEORY
<b>DURATION:</b> 2H	<b>MARKS:</b> 100

<b>FIRST OPPORTUNITY EXAMINATION QUESTION PAPER</b>	
<b>EXAMINER(S)</b>	MR. JULIUS SILAA MR. MBAUNGURAIJE TJUKUZU MR. PETRUS KATAMBO MR. IMMANUEL NAMPALA MR JACKSON NGHIDULIKA MS. SEPISO CHIKURUWO MR. ANDREAS AMUKWA
<b>MODERATOR:</b>	DR. SEBASTIAN MUKUMBIRA

**THIS QUESTION PAPER CONSISTS OF 6 PAGES**

(Excluding this front page)

**INSTRUCTIONS**

1. Answer ALL the questions on the answer scripts.
2. Write clearly and neatly.
3. Number the answers clearly.

**PERMISSIBLE MATERIALS**

1. None.

**SECTION A [15 MARKS]: Each Question Weighs 1 Mark.**

Indicate whether each of the following statements is True or False

1. The Direct Memory Access (DMA) technique allows the I/O module and main memory to transfer data directly, without processor involvement. True / False
2. The binary system, while convenient for computers, is extremely cumbersome for humans. True / False
3. SRAM is used as the building block for level 1 cache memory in computer systems. True / False
4. Addition and subtraction in two's complement notation can be performed by treating numbers as if they are unsigned integers. True / False
5. Instruction pipelining boosts performance but requires careful design for optimal results and reasonable complexity. True / False
6. Machine parallelism enables independent instructions to be executed simultaneously by overlapping their execution. True / False
7. Interrupt is one of the five states in a process's lifecycle. True / False
8. RISC processors are more responsive to interrupts because interrupts are checked between elementary operations. True / False
9. Paging is typically visible to programmers and is used for organizing programs, data, and managing privileges and protection attributes. True / False
10. The XOR operator yields false if both operands are true. True / False
11. It is not possible to connect I/O controllers directly to the system bus. True / False
12. Organizational attributes consist of hardware details that are transparent to the programmer. True / False
13. In a system without virtual memory, the effective address is a virtual address or a register. True / False
14. Binary notation is more compact than hexadecimal notation. True / False
15. AGP expansion cards found on the motherboard are superior to PCI Express (PCIe). True / False

**SECTION B [15 MARKS]: Each Question Weighs 1 Mark.**

**Choose the correct for each of the following:**

1. In floating-point representation, what occurs when the significand cannot represent a number due to insufficient bits?
  - A. Exponent overflow
  - B. Exponent underflow
  - C. Significand overflow
  - D. Significand underflow

2. What operating system function manages the allocation of CPU time to different processes?
  - A. Memory management
  - B. Process scheduling
  - C. File system management
  - D. Device management
3. What is the base (or radix) of the hexadecimal number system?
  - A. 2
  - B. 8
  - C. 10
  - D. 16
4. In a binary number, what is the term for the rightmost digit?
  - A. Most significant digit
  - B. Least significant digit
  - C. Base digit
  - D. Radix digit
5. In which context is the precision of a fixed-point number format typically determined?
  - A. Hardware design
  - B. Software configuration
  - C. User input
  - D. Data transmission
6. Operating system control Which properties do all semiconductor memory cells share?
  - A. They exhibit two stable states which can be used to represent
  - B. Binary 1 and 0
  - C. They are capable of being written into to set the state
  - D. All of the above
7. A \_\_\_\_\_ serves as the channel for communication between the CPU, main memory, and input/output devices.
  - A. system interconnection
  - B. CPU interconnection
  - C. peripheral
  - D. processor
8. The \_\_\_\_\_ is responsible for determining both the opcode and the operand specifiers.
  - A. decode instruction
  - B. fetch operands
  - C. calculate operands
  - D. execute instruction
9. A \_\_\_\_\_ is a schedulable unit of work inside a process, complete with its own processor context and stack data area.
  - A. Process
  - B. Process switch
  - C. Thread
  - D. Thread switch

10. The \_\_\_\_\_ is the processor memory component that helps boost processor performance.
- A. DDR3
  - B. DDR2
  - C. DDR4
  - D. Level 2 cache
11. Which of the following statements best compares Amdahl's Law and Moore's Law in the context of computer system performance improvement?
- A. Amdahl's Law predicts the maximum improvement in computing speed by increasing parallel processing, while Moore's Law observes the exponential growth in CPU clock speed.
  - B. Amdahl's Law concerns the theoretical speedup from parallelization, whereas Moore's Law describes the doubling of transistors on integrated circuits approximately every two years.
  - C. Both Amdahl's Law and Moore's Law are only applicable to hardware advancements and do not affect software performance.
  - D. Amdahl's Law explains the increase in transistor density, while Moore's Law explains the limits of parallel processing
12. Which of these interrelated factors are involved in determining how addressing bits are used?
- A. number of operands
  - B. number of register sets
  - C. address range
  - D. all of the above
13. The simplest and most basic type of machine instruction is the \_\_\_\_\_ instruction.
- A. conversion
  - B. data transfer
  - C. arithmetic
  - D. logical
14. \_\_\_\_\_ are components in digital circuits that manage the routing of signals and data.
- A. Multiplexers
  - B. Program counters
  - C. Flip-flops
  - D. Gates
15. A cache line contains a \_\_\_\_\_ to indicate which specific block of data is currently stored.
- A. cache
  - B. hit
  - C. tag
  - D. locality

**SECTION C [70 MARKS]: Comprehension Questions**

**Question 1**

**[10 marks]**

Complete the table below by summarizing the defining technology and at least two characteristics for each computer generation (First to Fifth).

<i>Generation Period</i>		<i>Defining Technology</i>	<i>Characteristic 1</i>	<i>Characteristic 2</i>	<i>Example</i>
<i>First</i>	<i>1940s–1950s</i>				<i>ENIAC *</i>
<i>Second</i>	<i>1950s–1960s</i>				<i>IBM 1401 *</i>
<i>Third</i>	<i>1960s–1970s</i>				<i>IBM System/360 *</i>
<i>Fourth</i>	<i>1970s–present</i>				<i>Apple II *</i>
<i>Fifth</i>	<i>Present–beyond</i>				<i>IBM Watson *</i>

*Note: Characteristics may include main memory, secondary storage, size, power consumption, reliability, cost/affordability, speed/efficiency, or programming languages.*

- *Marking allocation:*
  - *Defining Technology: 1 mark per generation (1 × 5 = 5 marks)*
  - *One Characteristic: 0.5 marks per generation (0.5 × 5 = 2.5 marks)*
  - *One Additional Characteristic: 0.5 marks per generation (0.5 × 5 = 2.5 marks)*
  - *Total: 10 marks*

**Question 2**

**[14 marks]**

- a) List and discuss the four structural components of a CPU. (8 marks)
- b) The von Neumann architecture, which is also known as Princeton architecture, is a computer model based on the 1945 description by the mathematician and physicist John von Neumann and others in the First Draft of a Report on the EDVAC.
- c) Briefly outline his three main ideas (no diagram is required). (6 marks)

**Question 3**

**[8 marks]**

- a) Describe your understanding of the following virtual memory techniques (6 marks)
- i) swapping
  - ii) paging
  - iii) demand paging
- b) What is the primary benefit of using a virtual memory management system? (2 marks)

**Question 4**

**[10 marks]**

A modern smartphone has 16 GB of memory. This memory is "word-addressable," meaning each word in memory has a unique address.

- a) If each word in memory has its own address, how many total words can be stored in this smartphone's memory? (Assume a standard word size of 4 bytes). (4 marks)
- b) Imagine this memory is organized into blocks, where each block holds 256 words. How many blocks would the smartphone's memory have? (3 marks)
- c) If we use a "direct-mapped cache scheme," where each memory block is assigned to one specific line in the cache, how many cache lines would be needed to hold all the blocks from part (b)? (3 marks)

**Question 5**

**[6 marks]**

Let's say you want to design a circuit that controls a fan (output F) in a smart thermostat when two sensor inputs A (temperature high) and B (humidity high) are applied.

A	B	F
0	0	0
0	1	1
1	0	1
1	1	0

- a) Provide a canonical Boolean function ( F ) for the circuit above (2 marks)
- b) Suppose this Function does not require any further minimization. Can you create a visual representation(circuit) of this Boolean function using AND,NOT and OR gates? (4 marks)

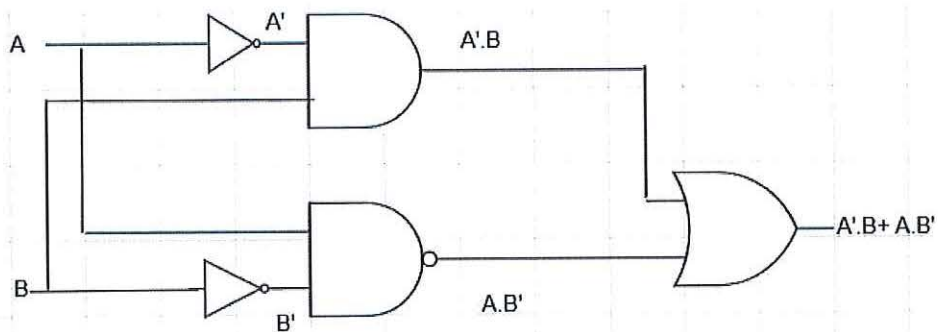

**Question 6**

**[15 marks]**

- a) Examine the provided circuit diagram. Can you identify the specific type of circuit it represents? (2 marks)

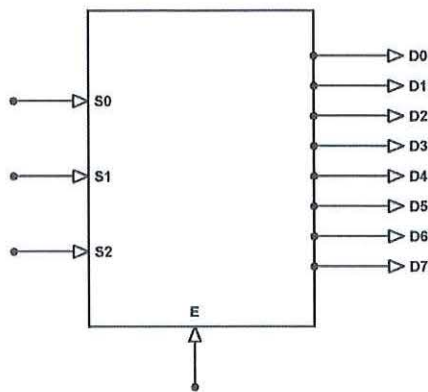

In a this circuit with outputs D0 through D7, what are the roles of input ( S1,S2,S3) and the input (E)? (4 marks)

b) Can you provide a real-world example of how this specific circuit might be used within a computer memory system? (3 marks)

c) Construct a comprehensive truth table for the circuit shown in the diagram. This table should clearly list all possible input and and their corresponding output combinations (6 marks)

**Question 7**

**[17 marks]**

Different computer architectures have different instruction sets, influencing how efficiently and flexibly they can perform tasks.

a) Give an example of a typical instruction that a computer's processor might execute. (2marks)

b) Based on your example in part (a), what are the three essential pieces of information that every computer instruction needs to include? (3marks)

c) Explain the basic steps involved in how a computer processes a single instruction. You can use a diagram to illustrate these steps. (6 marks)

d) How does a computer instruction know where to find the data it needs to work with? Explain three common ways and give an example of each. (6 marks)

\*\*\*\*\*END OF PAPER\*\*\*\*\*